

The information in this document is subject to change without notice and should not be construed as a commitment by ABB. ABB assumes no responsibility for any errors that may appear in this document.

Except as may be expressly stated anywhere in this document, nothing herein shall be construed as any kind of guarantee or warranty by ABB for losses, damages to persons or property, fitness for a specific purpose or the like.

In no event shall ABB be liable for incidental or consequential damages arising from use of this document.

This document and parts thereof must not be reproduced or copied without ABB's written permission, and contents thereof must not be imparted to a third party nor be used for any unauthorized purpose. Contravention will be prosecuted.

Additional copies of this document may be obtained from ABB at its then current charge.

© Copyright 2015 ABB ALL right reserved.

ABB AB

SE-721 68 Västerås  
Sweden

We reserve all rights in this document and in the information contained therein. Reproduction, use or disclosure to third parties without express authority is strictly forbidden. © Copyright 2003 ABB

Latest revision: 2015			Lab/Office: PRE	PROCESS INTERFACE ARISTOMIG COPYRIGHT PAGE	Status: Approved	Plant: = Location: + Sublocation: +	Document no. 3HEA803113-001	Rev. Ind 03	Page 1 Next 2 Total 23
Prepared by, date: PRE/MB, 2015-11-30	Approved by, date: PRE/PC, 2015-11-30								

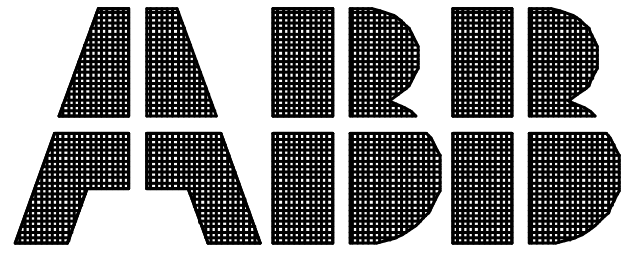

Description : PROCESS INTERFACE ARISTOMIG  
 Drawing number : 3HEA803113-001  
 Drawing version : 03  
 Date : 2015-10-28

Customer :  
 Year of construction : 2015  
 :  
 :  
 :  
 :  
 :  
 :

Drawn by : PRE/MB  
 Number of pages : 23  
 :  
 :  
 :  
 :

We reserve all rights in this document and in the information contained therein. Reproduction, use or disclosure to third parties without express authority is strictly forbidden. © Copyright 2003, ABB

Latest revision:  
 2015  
 Rev 03: Updated with TC2013  
 Prepared by, date: PRE/MB, 2015-11-30 | Approved by, date: PRE/PC, 2015-11-30



Lab/Office:  
 PRE

PROCESS INTERFACE ARISTOMIG  
 TITLE PAGE

Status: Approved  
 Plant: =  
 Location: +  
 Sublocation: +

Document no.	Rev. Ind	Page 2
3HEA803113-001	03	Next 3
		Total 23



1  
2  
3  
4  
5  
6  
7  
8

MAINS  
SUPPLY

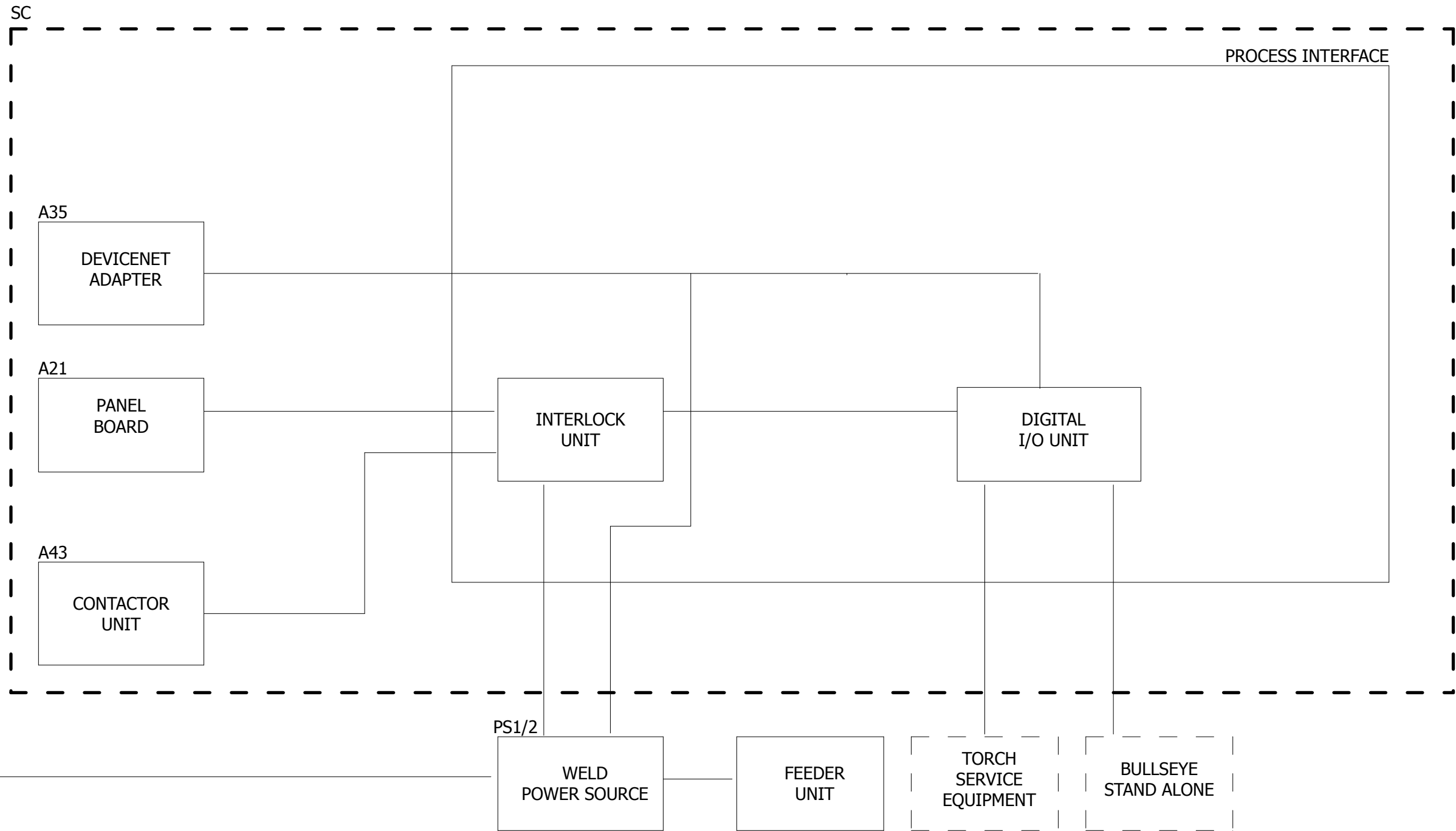

Latest revision:  
2015

Prepared by, date: PRE/MB, 2015-11-30 | Approved by, date: PRE/PC, 2015-11-30



Lab/Office:  
PRE

PROCESS INTERFACE ARISTOMIG  
BLOCK DIAGRAM

Status:  
Approved

Plant: =  
Location: +  
Sublocation: +

Document no.  
3HEA803113-001

Rev. Ind  
03

Page 4  
Next 5  
Total 23



SEE EL.DWGS FOR THE IRC5 CONTROLLER

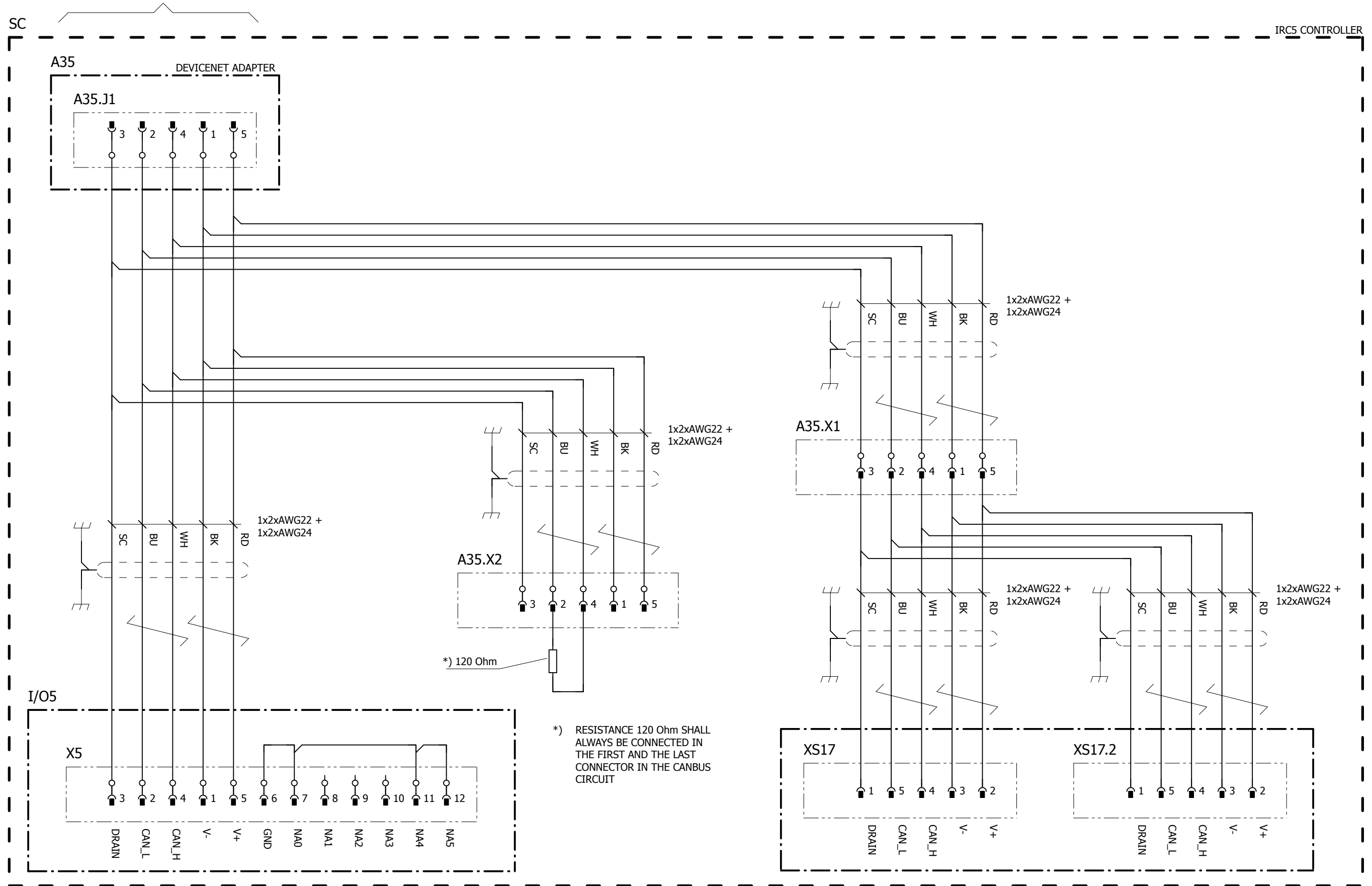

We reserve all rights in this document and in the information contained therein. Reproduction, use or disclosure to third parties without express authority is strictly forbidden. © Copyright 2003 ABB

Latest revision: 2015  
 Prepared by, date: PRE/MB, 2015-11-30  
 Approved by, date: PRE/PC, 2015-11-30



Lab/Office: PRE

PROCESS INTERFACE ARISTOMIG  
 CAN BUS

Status: Approved

Plant: =  
 Location: +  
 Sublocation: +

Document no. 3HEA803113-001

Rev. Ind 03  
 Page 6  
 Next 7  
 Total 23

We reserve all rights in this document and in the information contained therein. Reproduction, use or disclosure to third parties without express authority is strictly forbidden. © Copyright 2003 ABB

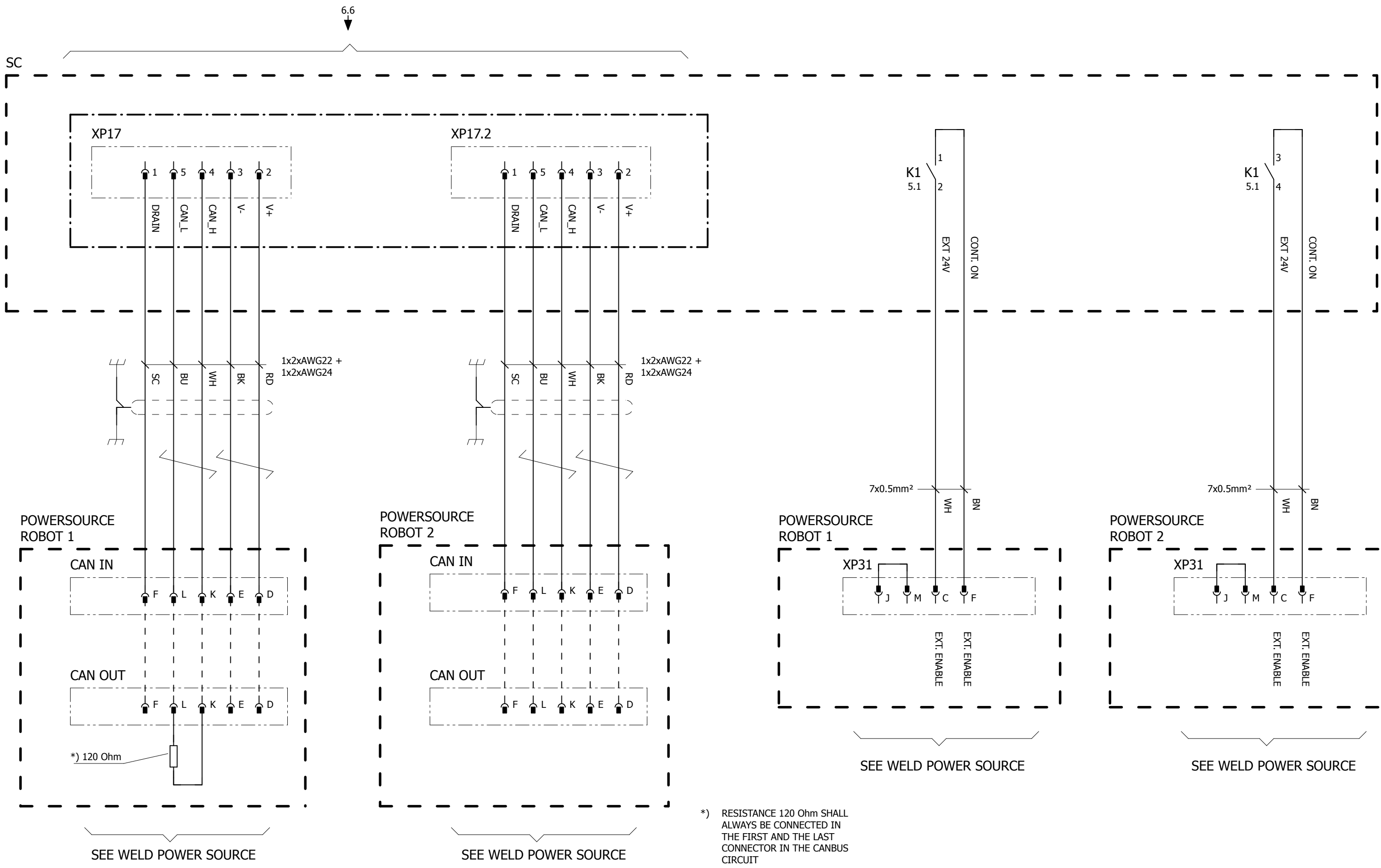

SEE EL.DWGS FOR THE IRC5 CONTROLLER

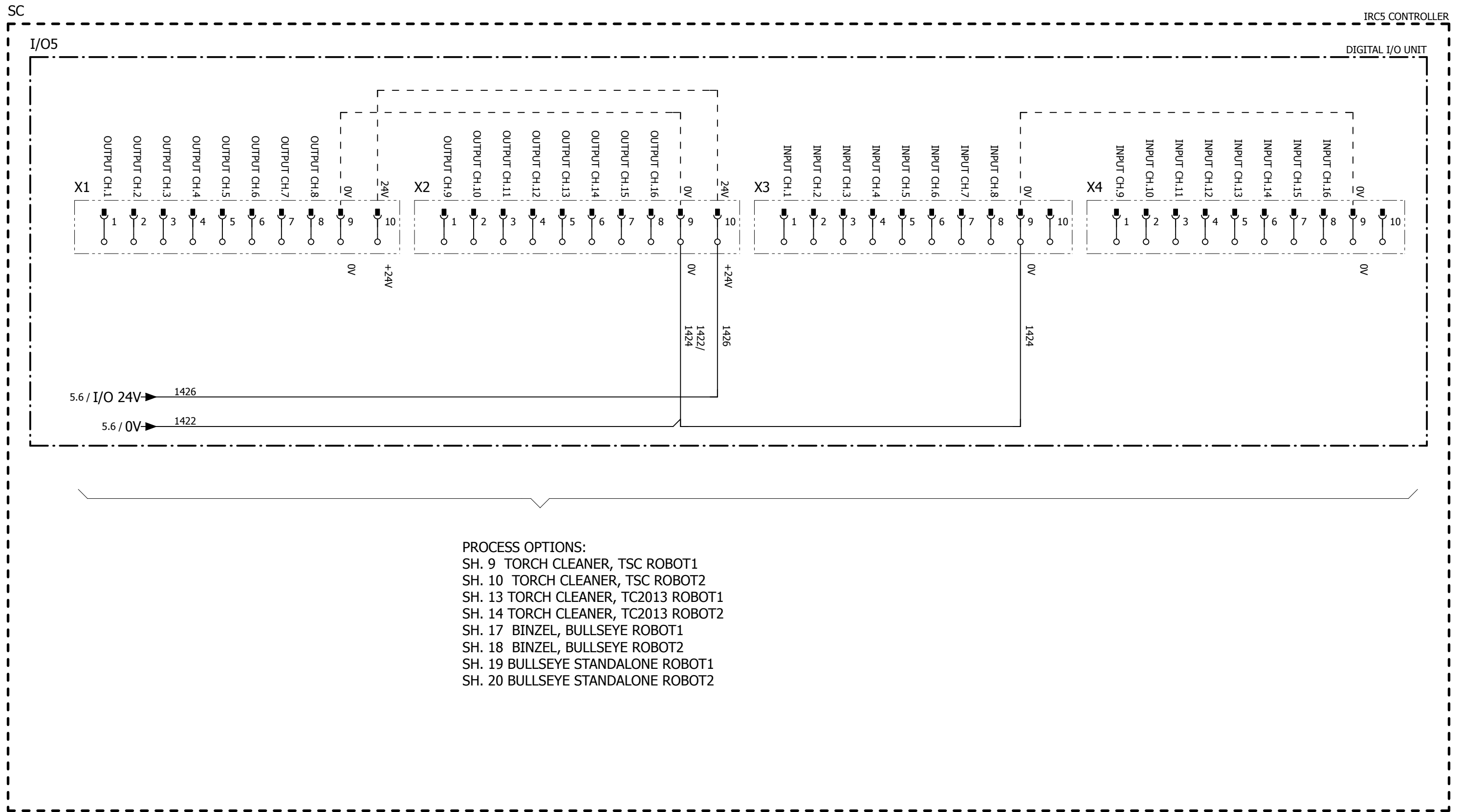

PROCESS OPTIONS:

- SH. 9 TORCH CLEANER, TSC ROBOT1
- SH. 10 TORCH CLEANER, TSC ROBOT2
- SH. 13 TORCH CLEANER, TC2013 ROBOT1
- SH. 14 TORCH CLEANER, TC2013 ROBOT2
- SH. 17 BINZEL, BULLSEYE ROBOT1
- SH. 18 BINZEL, BULLSEYE ROBOT2
- SH. 19 BULLSEYE STANDALONE ROBOT1
- SH. 20 BULLSEYE STANDALONE ROBOT2

We reserve all rights in this document and in the information contained therein. Reproduction, use or disclosure to third parties without express authority is strictly forbidden. © Copyright 2003 ABB

Latest revision: 2015	Rev 03: Updated with TC2013	Prepared by, date: PRE/MB, 2015-11-30	Approved by, date: PRE/PC, 2015-11-30
--------------------------	-----------------------------	---------------------------------------	---------------------------------------



Lab/Office:  
PRE

PROCESS INTERFACE ARISTOMIG  
CONNECTION EXT. EQUIPMENT

Status: Approved	Plant: = Location: + Sublocation: +	Document no. 3HEA803113-001	Rev. Ind 03	Page 8 Next 9 Total 23
---------------------	-------------------------------------------	--------------------------------	----------------	------------------------------



We reserve all rights in this document and in the information contained therein. Reproduction, use or disclosure to third parties without express authority is strictly forbidden. © Copyright 2003 ABB

SEE EL.DWGS FOR THE IRC5 CONTROLLER

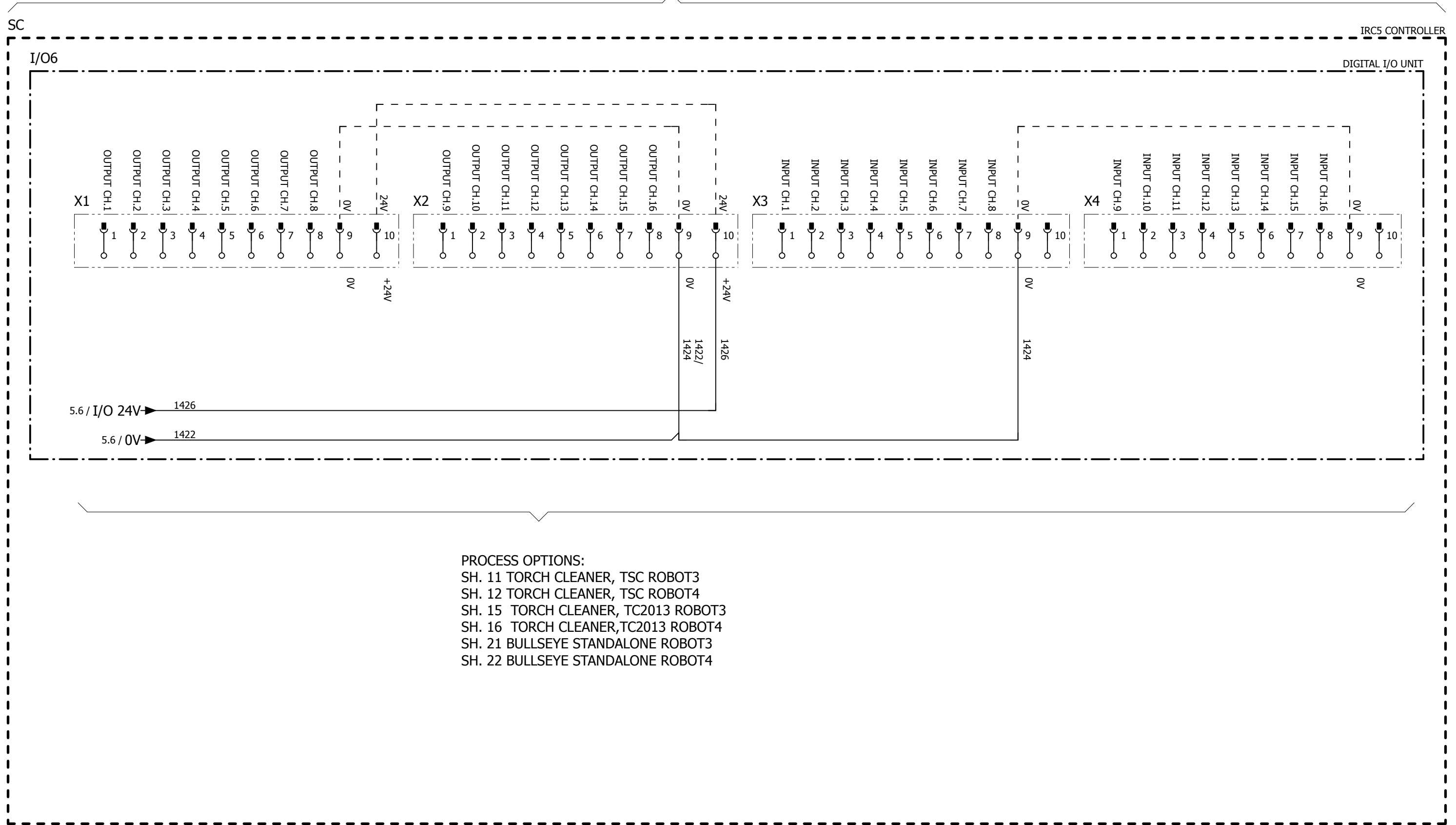

- PROCESS OPTIONS:  
 SH. 11 TORCH CLEANER, TSC ROBOT3  
 SH. 12 TORCH CLEANER, TSC ROBOT4  
 SH. 15 TORCH CLEANER, TC2013 ROBOT3  
 SH. 16 TORCH CLEANER, TC2013 ROBOT4  
 SH. 21 BULLSEYE STANDALONE ROBOT3  
 SH. 22 BULLSEYE STANDALONE ROBOT4

Latest revision:  
 2015  
 Rev 03: Added connections for Robot 3 and Robot 4  
 Prepared by, date: PRE/MB, 2015-11-30 | Approved by, date: PRE/PC, 2015-11-30



Lab/Office:  
 PRE

PROCESS INTERFACE ARISTOMIG  
 CONNECTION EXT. EQUIPMENT

Status: Approved  
 Plant: =  
 Location: +  
 Sublocation: +  
 Document no. 3HEA803113-001  
 Rev. Ind 03  
 Page 9  
 Next 10  
 Total 23

We reserve all rights in this document and in the information contained therein. Reproduction, use or disclosure to third parties without express authority is strictly forbidden. © Copyright 2003 ABB

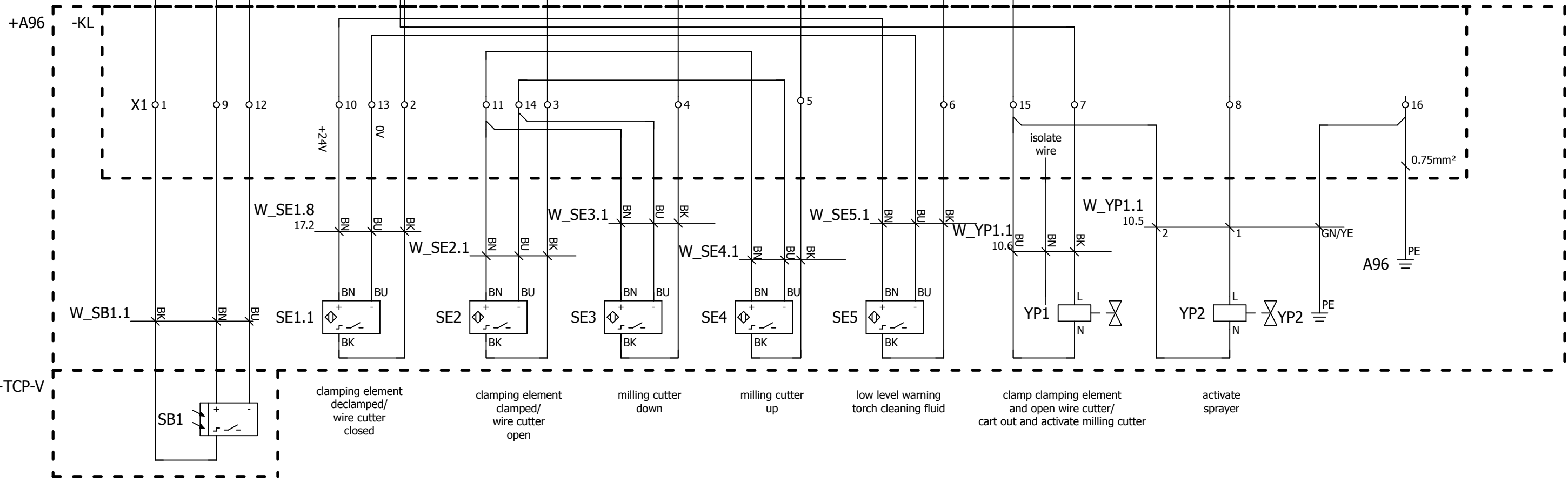
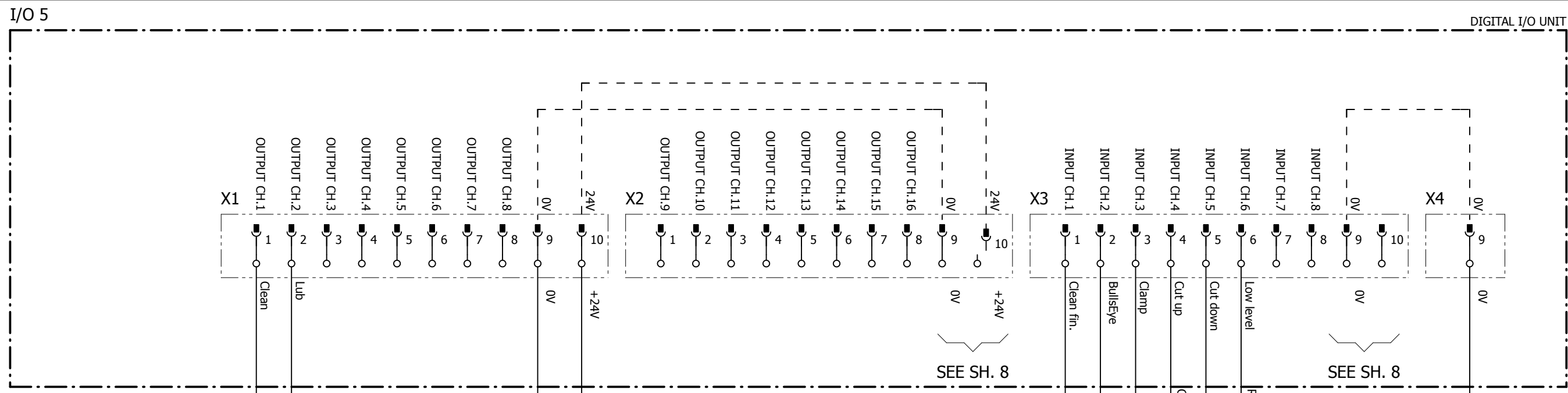

Latest revision: 2015  
 Rev 03: Updated with TC2013  
 Prepared by, date: PRE/MB, 2015-11-30  
 Approved by, date: PRE/PC, 2015-11-30



Lab/Office: PRE

PROCESS INTERFACE ARISTOMIG  
 OPTION TORCH CLEANER  
 TSC ROBOT 1

Status: Approved

Plant: =  
 Location: +  
 Sublocation: +

Document no. 3HEA803113-001

Rev. Ind 03  
 Page 10  
 Next 11  
 Total 23

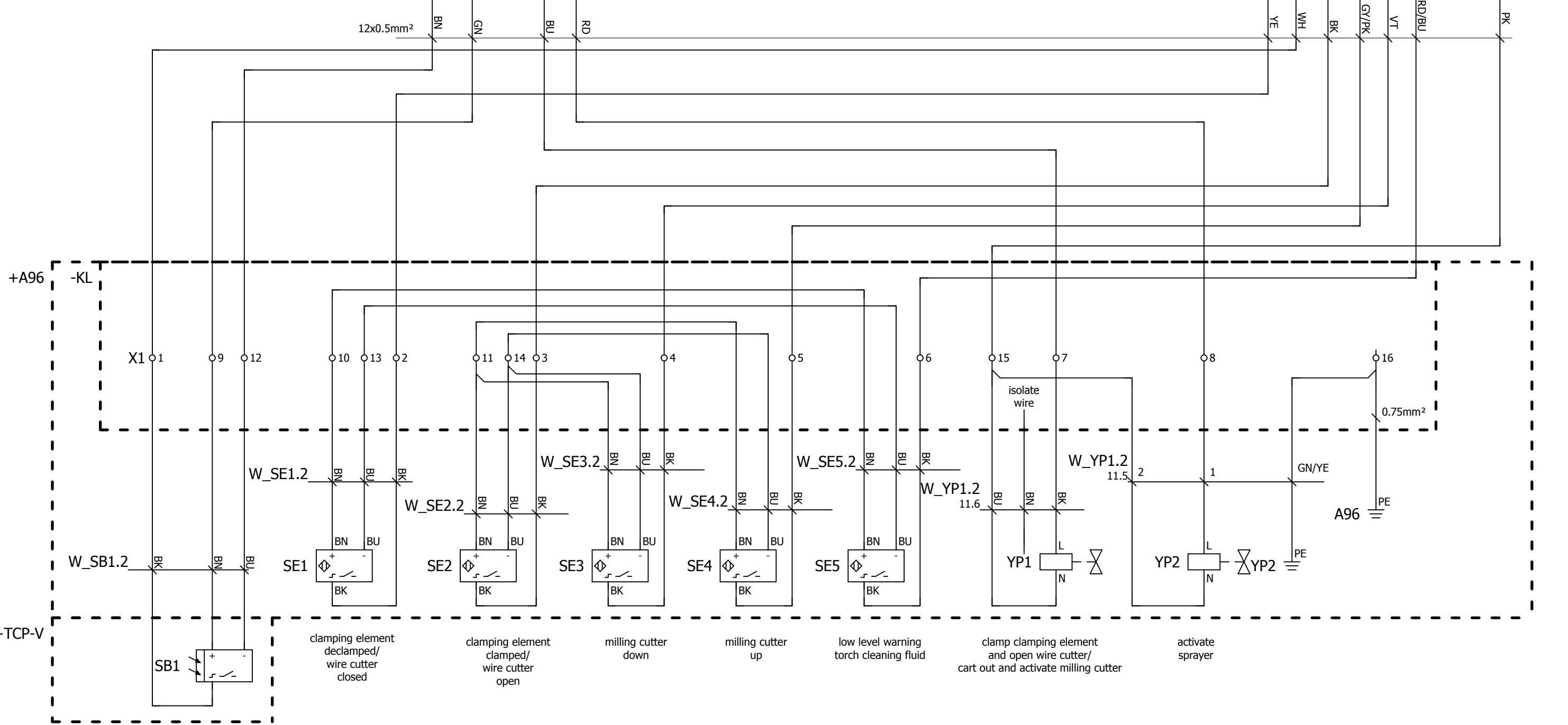
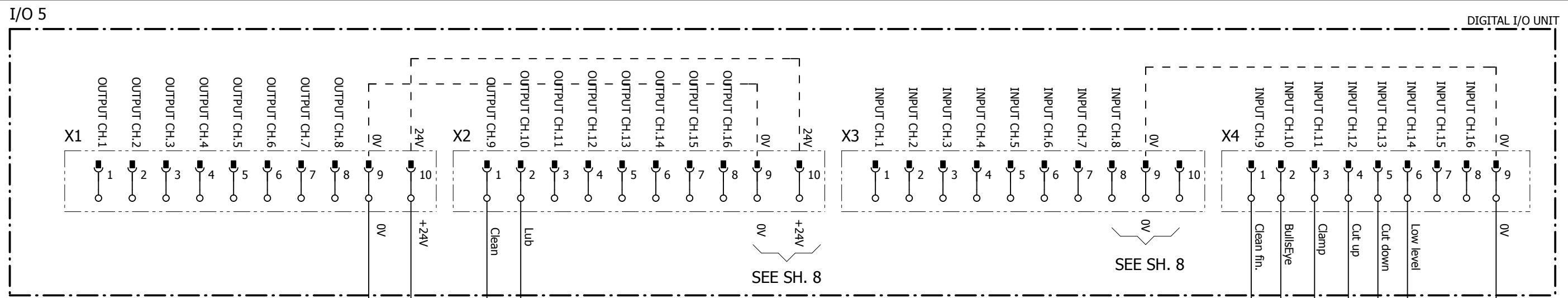

TORCH SERVICE CENTER

Latest revision:  
2015  
Rev 03: Updated with TC2013  
Prepared by, date: PRE/MB, 2015-11-30  
Approved by, date: PRE/PC, 2015-11-30



Lab/Office:  
PRE

PROCESS INTERFACE ARISTOMIG  
OPTION TORCH CLEANER  
TSC ROBOT 2

Status:  
Approved

Plant: =  
Location: +  
Sublocation: +

Document no.  
3HEA803113-001

Rev. Ind  
03  
Page 11  
Next 12  
Total 23

We reserve all rights in this document and in the information contained therein. Reproduction, use or disclosure to third parties without express authority is strictly forbidden. © Copyright 2003 ABB

We reserve all rights in this document and in the information contained therein. Reproduction, use or disclosure to third parties without express authority is strictly forbidden. © Copyright 2003, ABB

I/O 6

DIGITAL I/O UNIT

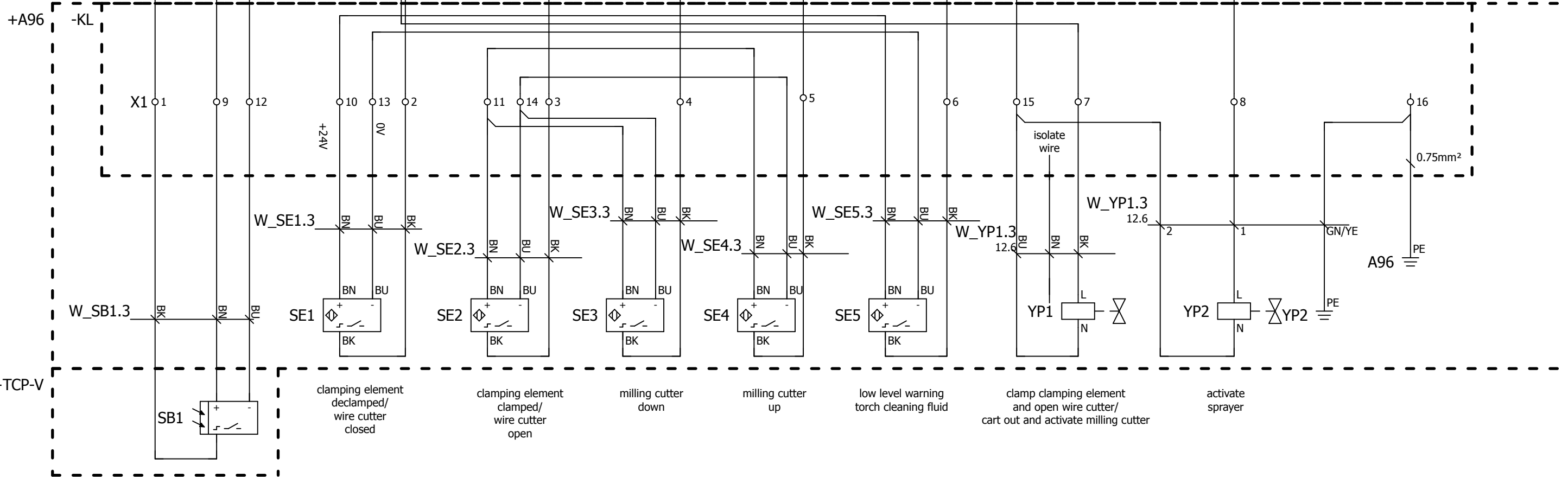
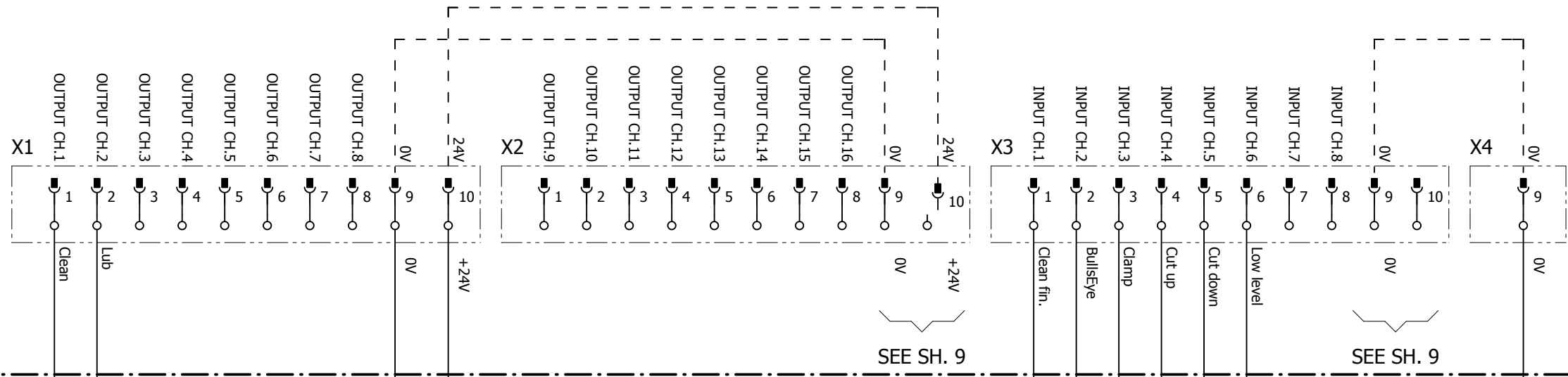

TORCH SERVICE CENTER

Latest revision: 2015	Approved by, date: PRE/PC, 2015-11-30
Rev 03: Added connections for Robot 3	
Prepared by, date: PRE/MB, 2015-11-30	



Lab/Office:  
PRE

PROCESS INTERFACE ARISTOMIG  
OPTION TORCH CLEANER  
TSC ROBOT 3

Status: Approved	Plant: = Location: + Sublocation: +
Document no. 3HEA803113-001	Rev. Ind 03
	Page 12 Next 13 Total 23

We reserve all rights in this document and in the information contained therein. Reproduction, use or disclosure to third parties without express authority is strictly forbidden. © Copyright 2003 ABB

I/O 6

DIGITAL I/O UNIT

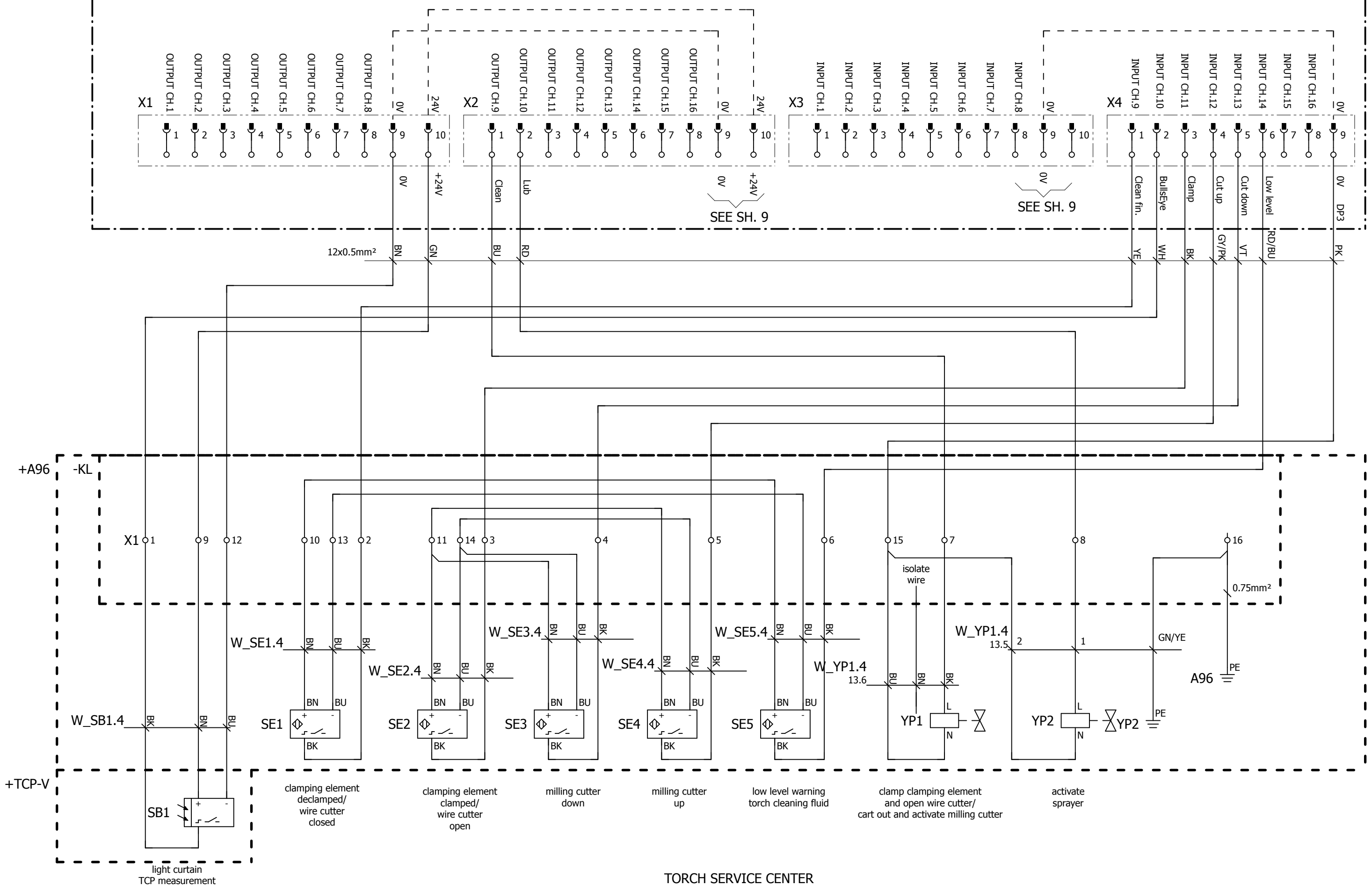

TORCH SERVICE CENTER

Latest revision:  
2015  
Rev 03: Added connections for Robot 4  
Prepared by, date: PRE/MB, 2015-11-30  
Approved by, date: PRE/PC, 2015-11-30



Lab/Office:  
PRE

PROCESS INTERFACE ARISTOMIG  
OPTION TORCH CLEANER  
TSC ROBOT 4

Status:  
Approved

Plant: =  
Location: +  
Sublocation: +

Document no.  
**3HEA803113-001**

Rev. Ind  
**03**  
Page 13  
Next 14  
Total 23

We reserve all rights in this document and in the information contained therein. Reproduction, use or disclosure to third parties without express authority is strictly forbidden. © Copyright 2003 ABB

I/O 5

DIGITAL I/O UNIT

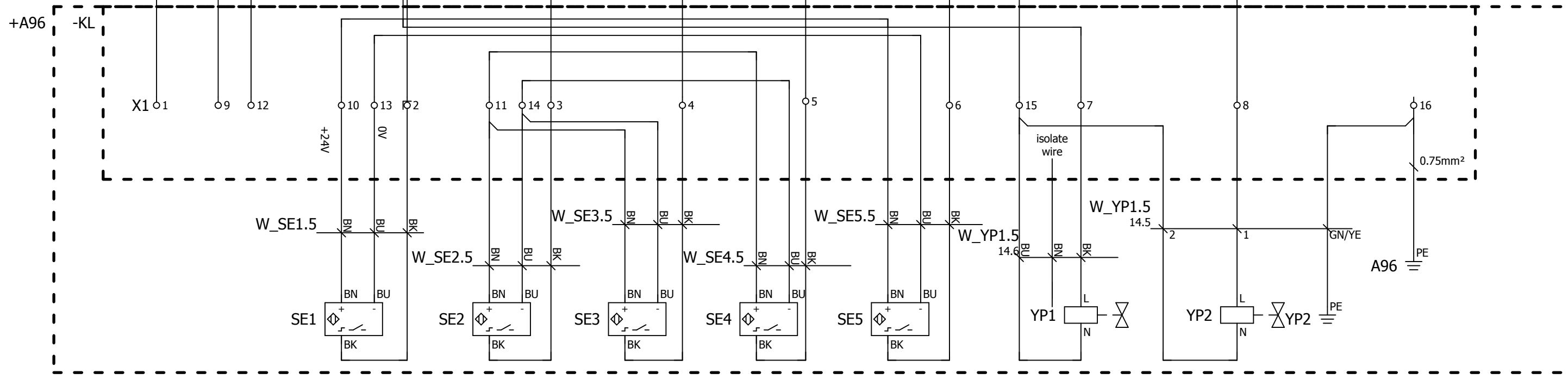
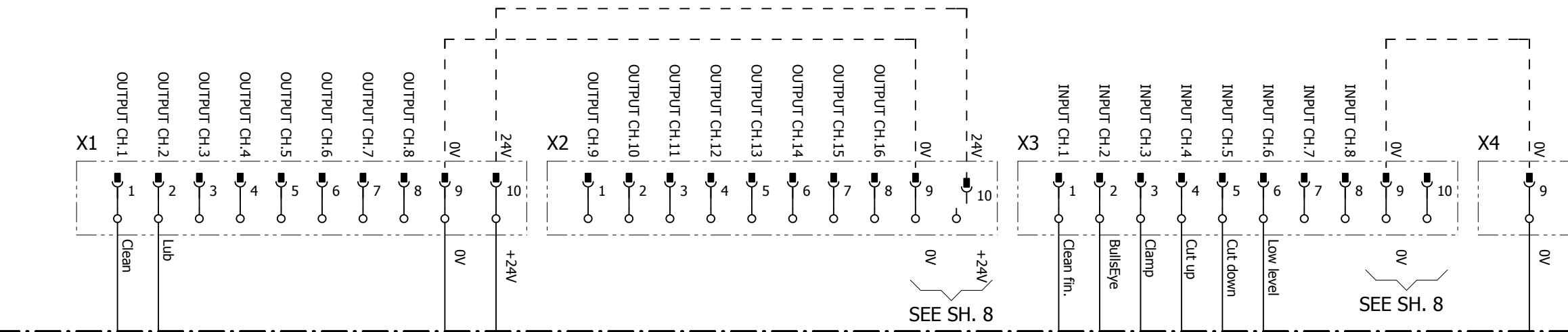

- clamping element  
declamped/  
wire cutter  
closed
- clamping element  
clamped/  
wire cutter  
open
- milling cutter  
down
- milling cutter  
up
- low level warning  
torch cleaning fluid
- clamp clamping element  
and open wire cutter/  
cart out and activate milling cutter
- activate  
sprayer

TORCH CLEANER TC2013

Latest revision:  
2015  
Rev 03: Updated with TC2013  
Prepared by, date: PRE/MB, 2015-11-30  
Approved by, date: PRE/PC, 2015-11-30



Lab/Office:  
PRE

PROCESS INTERFACE ARISTOMIG  
OPTION TORCH CLEANER  
TC2013 ROBOT 1

Status:  
Approved

Plant: =  
Location: +  
Sublocation: +

Document no. 3HEA803113-001  
Rev. 03  
Page 14  
Next 15  
Total 23

We reserve all rights in this document and in the information contained therein. Reproduction, use or disclosure to third parties without express authority is strictly forbidden. © Copyright 2003, ABB

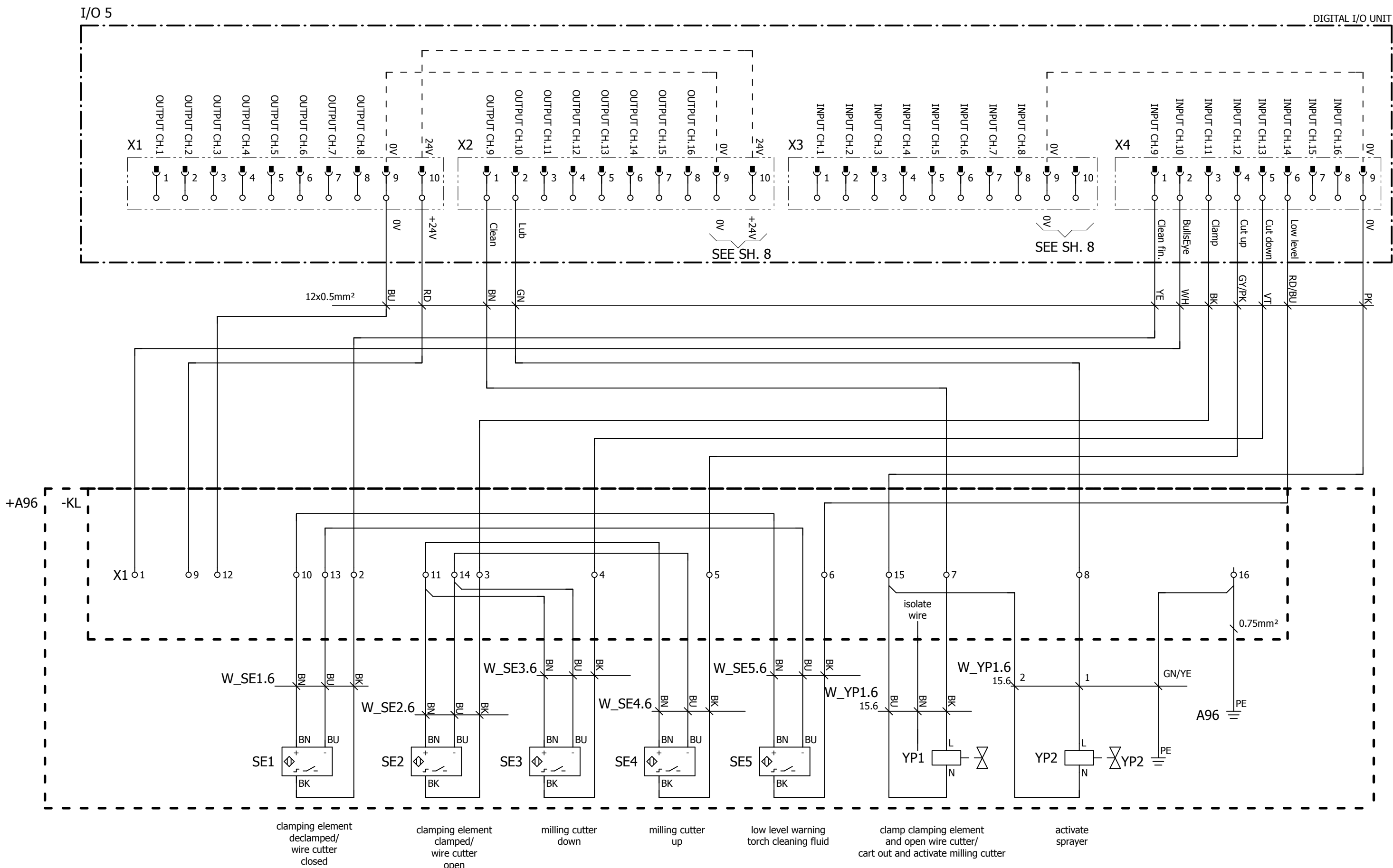

TORCH CLEANER TC2013

Latest revision: 2015  
 Rev 03: Updated with TC2013  
 Prepared by, date: PRE/MB, 2015-11-30  
 Approved by, date: PRE/PC, 2015-11-30



Lab/Office: PRE

PROCESS INTERFACE ARISTOMIG  
 OPTION TORCH CLEANER  
 TC2013 ROBOT 2

Status: Approved  
 Document no. 3HEA803113-001  
 Plant: =  
 Location: +  
 Sublocation: +  
 Rev. Ind 03  
 Page 15  
 Next 16  
 Total 23

We reserve all rights in this document and in the information contained therein. Reproduction, use or disclosure to third parties without express authority is strictly forbidden. © Copyright 2003 ABB

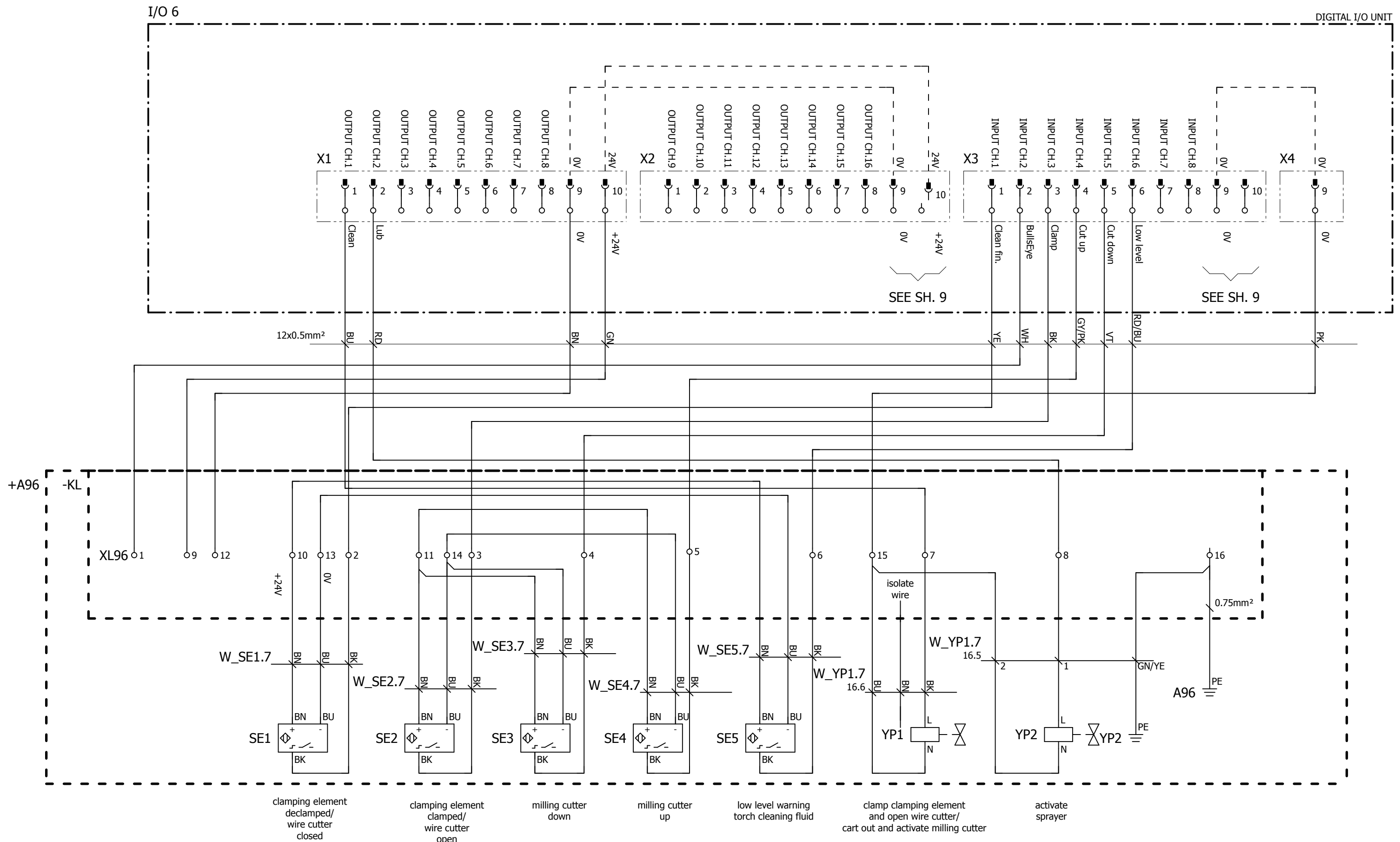

TORCH CLEANER TC2013

Latest revision: 2015  
 Rev 03: Added connections for Robot 3  
 Prepared by, date: PRE/MB, 2015-11-30  
 Approved by, date: PRE/PC, 2015-11-30



Lab/Office: PRE

PROCESS INTERFACE ARISTOMIG  
 OPTION TORCH CLEANER  
 TC2013 ROBOT 3

Status: Approved

Plant: =  
 Location: +  
 Sublocation: +

Document no. 3HEA803113-001  
 Rev. Ind 03  
 Page 16  
 Next 17  
 Total 23



We reserve all rights in this document and in the information contained therein. Reproduction, use or disclosure to third parties without express authority is strictly forbidden. © Copyright 2003 ABB

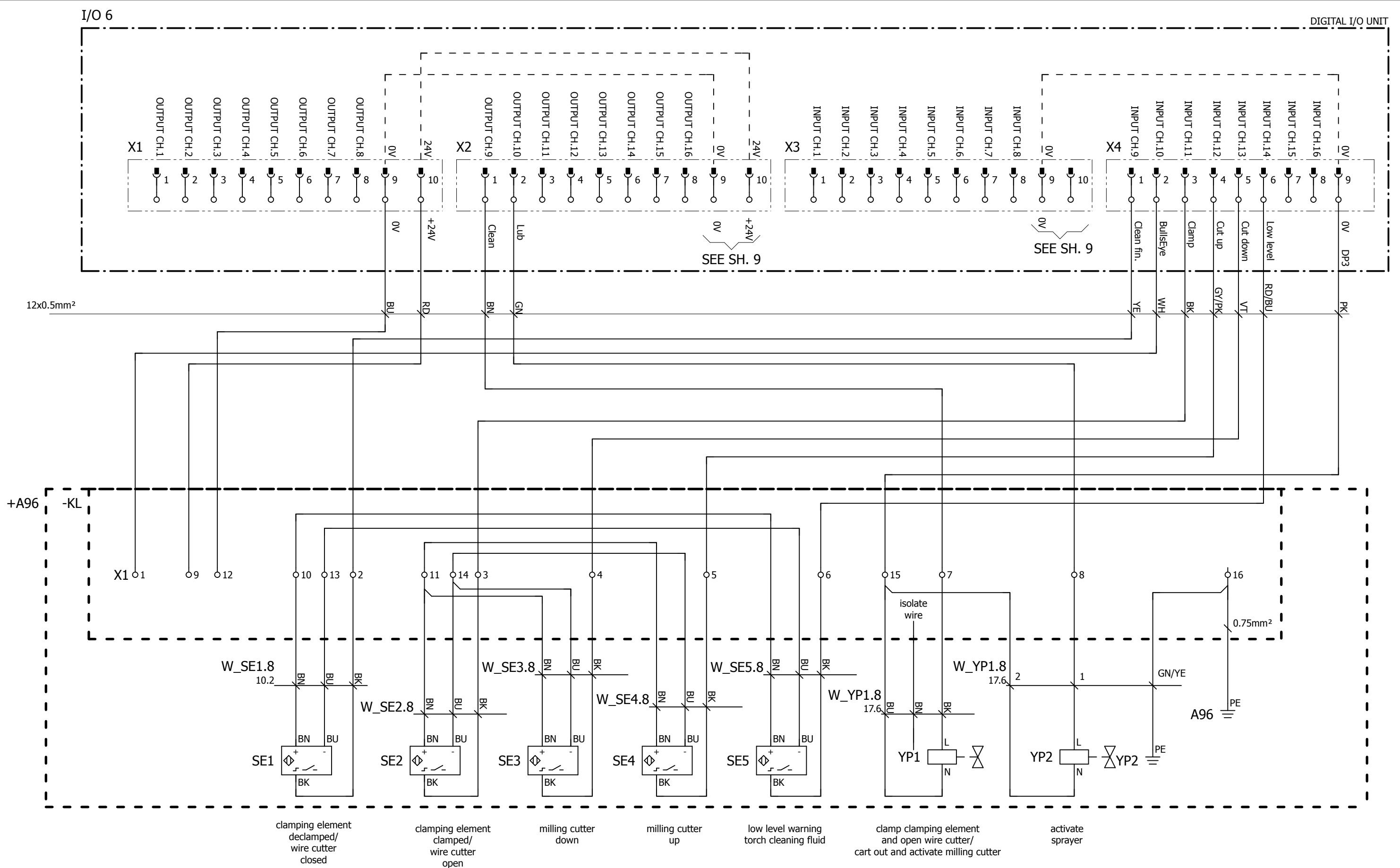

TORCH CLEANER TC2013

Latest revision:  
2015  
Rev 03: Added connections for Robot 4  
Prepared by, date: PRE/MB, 2015-11-30  
Approved by, date: PRE/PC, 2015-11-30



Lab/Office:  
PRE

PROCESS INTERFACE ARISTOMIG  
OPTION TORCH CLEANER  
TC2013 ROBOT 4

Status:  
Approved

Plant: =  
Location: +  
Sublocation: +

Document no. 3HEA803113-001  
Rev. Ind 03  
Page 17  
Next 18  
Total 23

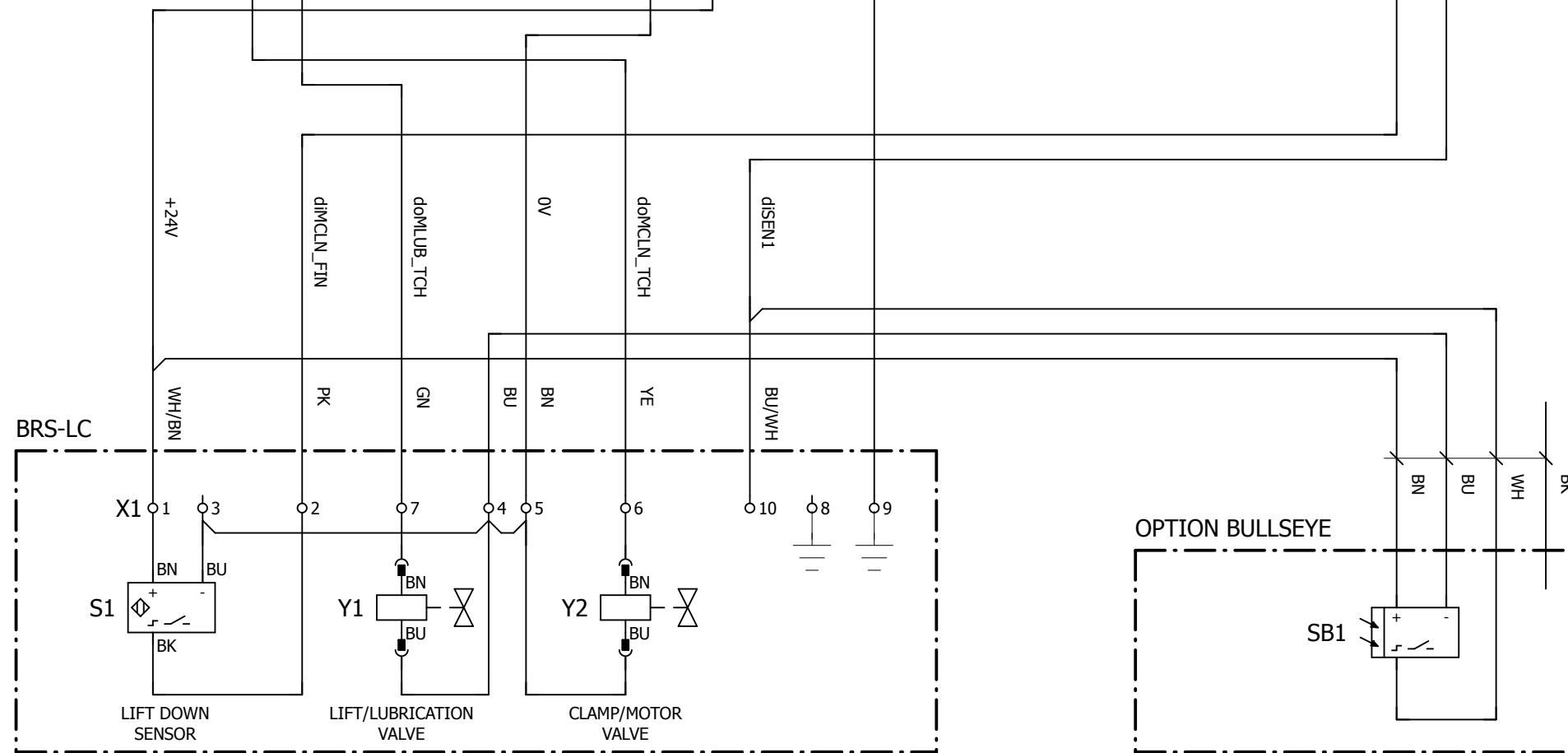
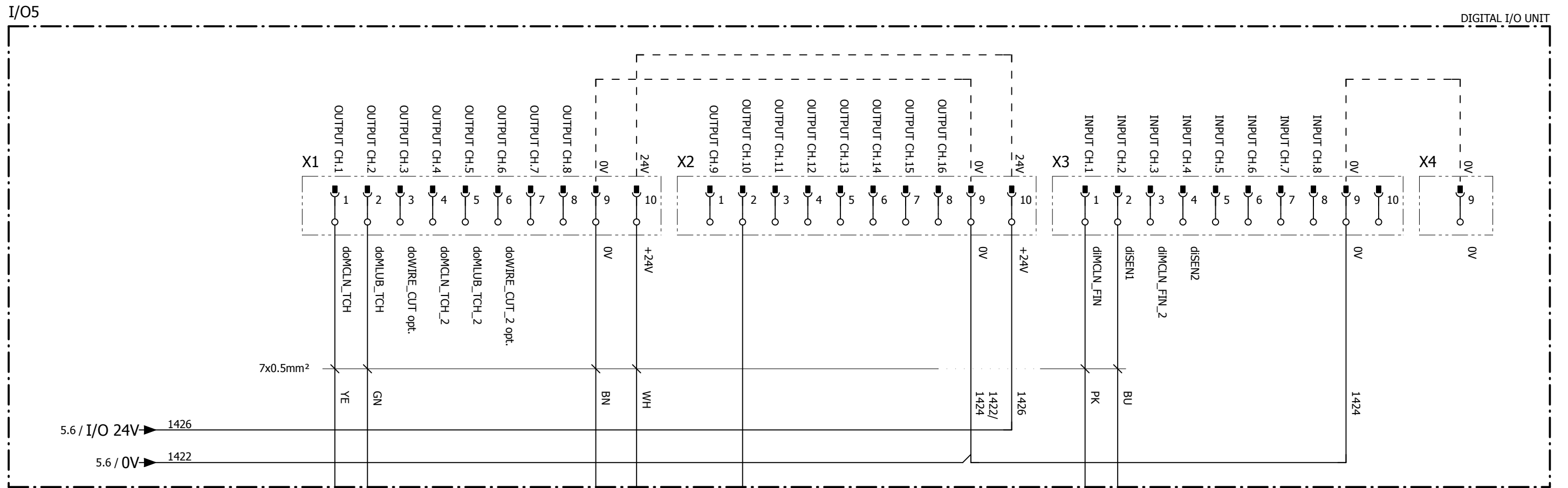

We reserve all rights in this document and in the information contained therein. Reproduction, use or disclosure to third parties without express authority is strictly forbidden. © Copyright 2003 ABB



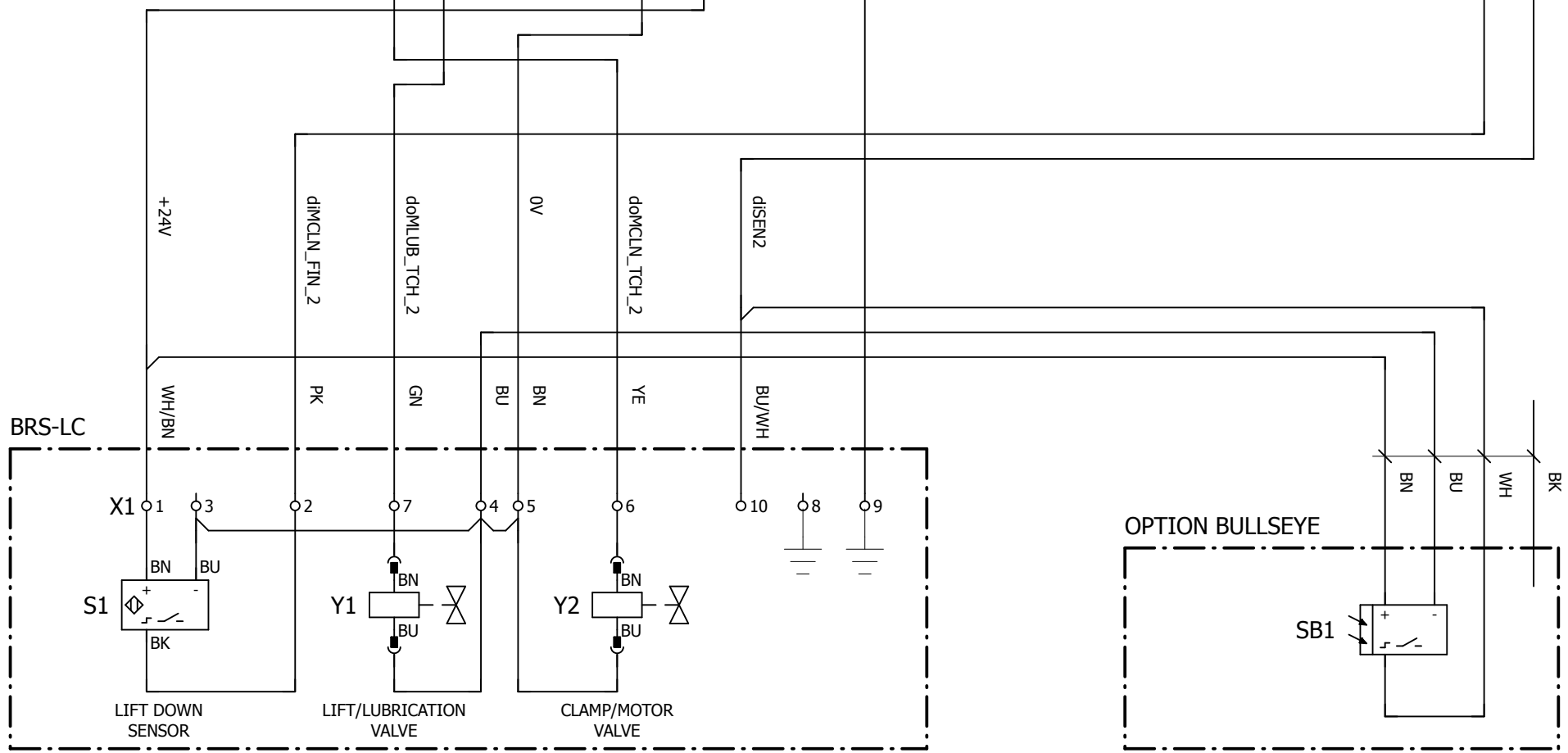
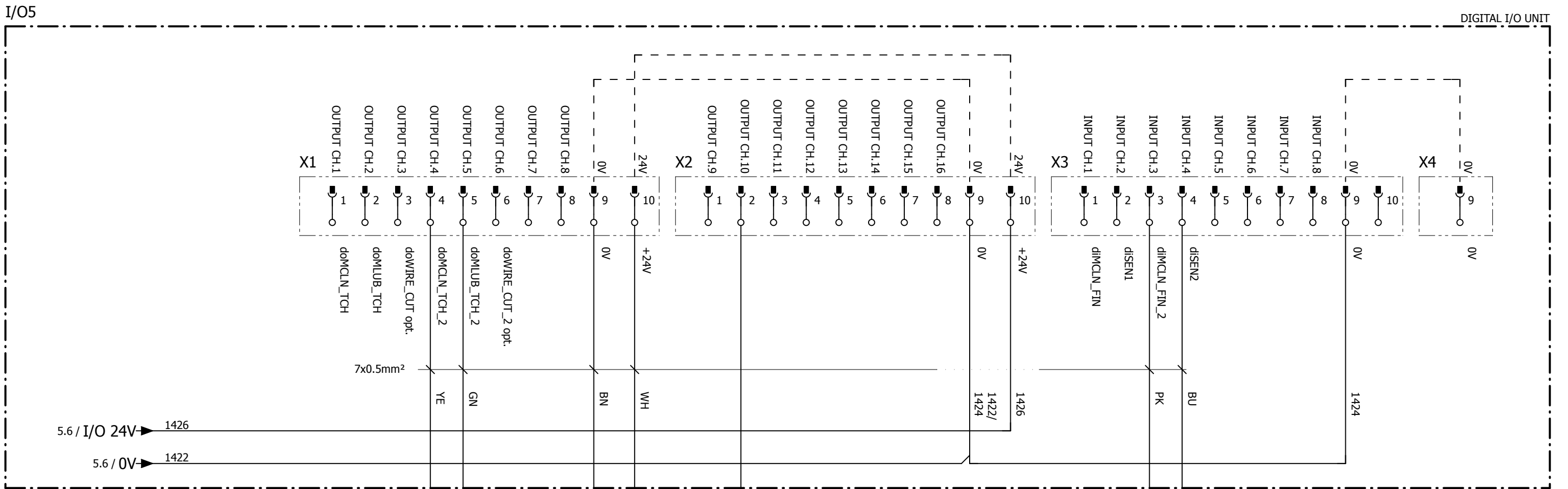

We reserve all rights in this document and in the information contained therein. Reproduction, use or disclosure to third parties without express authority is strictly forbidden. © Copyright 2003 ABB

Latest revision: 2015  
 Prepared by, date: PRE/MB, 2015-11-30  
 Approved by, date: PRE/PC, 2015-11-30



Lab/Office: PRE

PROCESS INTERFACE ARISTOMIG  
 OPTION TORCH CLEANER  
 BINZEL BULLSEYE ROBOT 2

Status: Approved	Plant: =	Location: +	Sublocation: +
Document no. 3HEA803113-001	Rev. Ind 03	Page 19	Next 20
		Total 23	

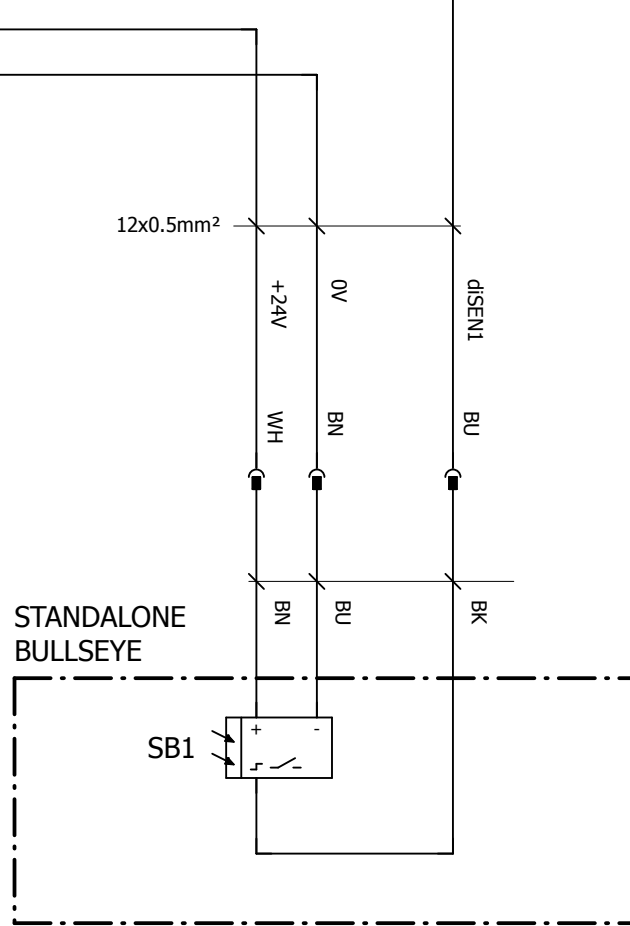
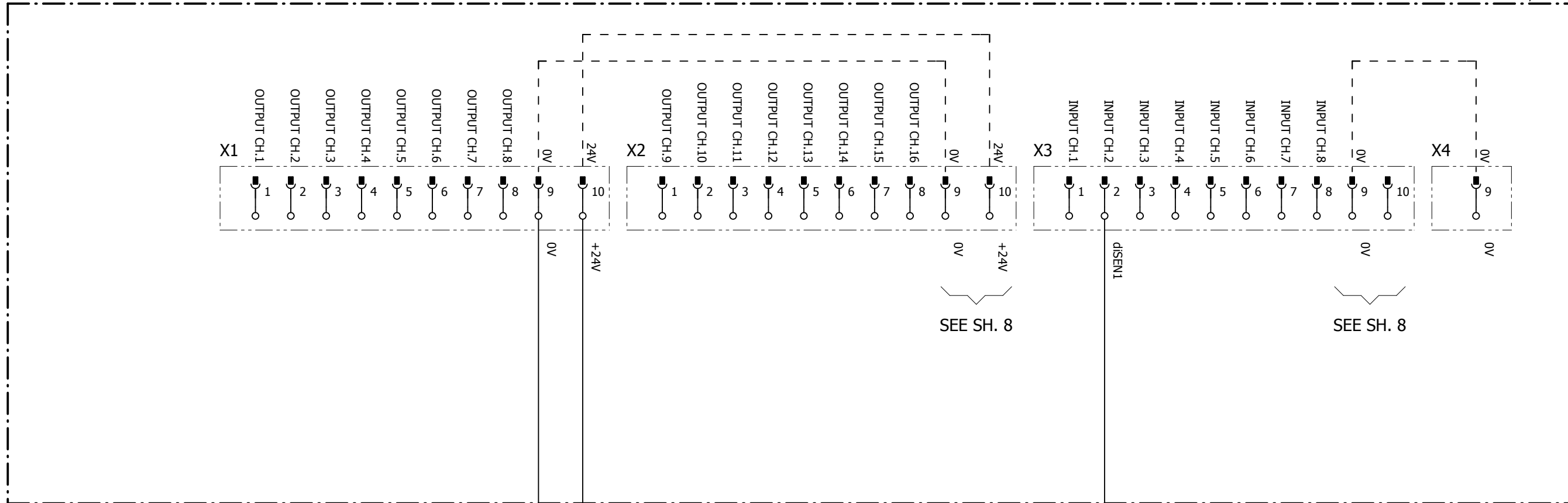

We reserve all rights in this document and in the information contained therein. Reproduction, use or disclosure to third parties without express authority is strictly forbidden. © Copyright 2003 ABB

Latest revision: 2015	Approved by, date: PRE/PC, 2015-11-30
Rev 03: Updated with TC2013	
Prepared by, date: PRE/MB, 2015-11-30	



Lab/Office:  
PRE

PROCESS INTERFACE ARISTOMIG  
OPTION BULLSEYE STANDALONE  
ROBOT 1

Status: Approved	Plant: = Location: + Sublocation: +
Document no. 3HEA803113-001	Rev. Ind 03
	Page 20 Next 21 Total 23

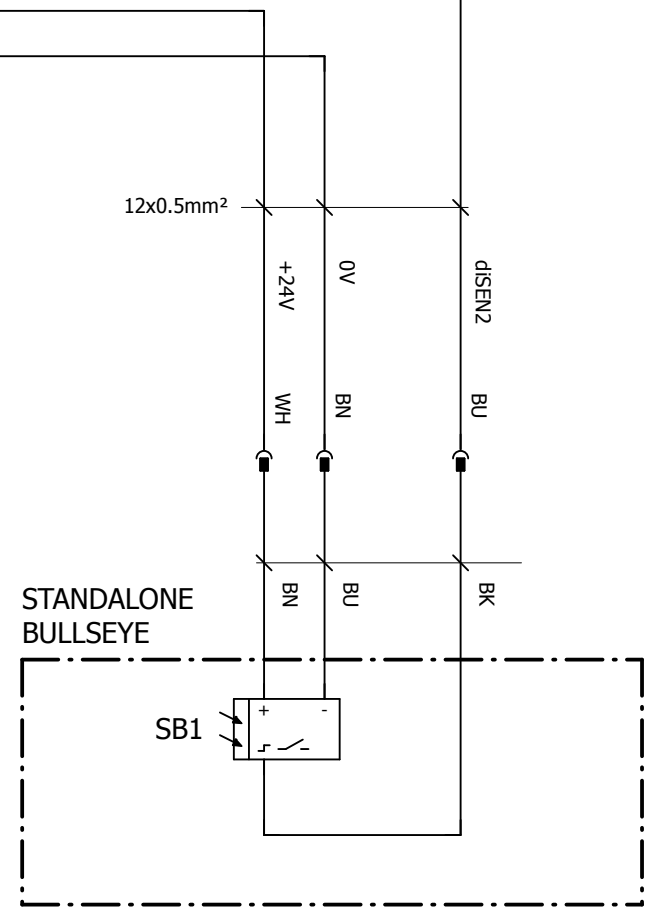
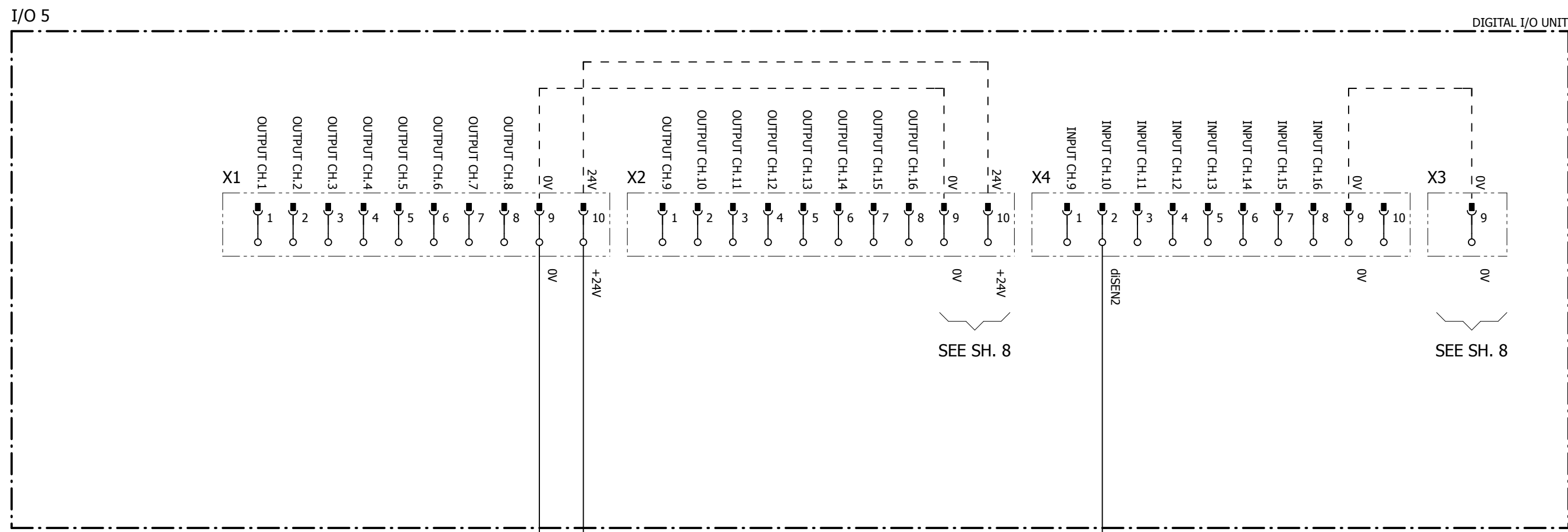

We reserve all rights in this document and in the information contained therein. Reproduction, use or disclosure to third parties without express authority is strictly forbidden. © Copyright 2003 ABB

Latest revision:  
2015  
Rev 03: Updated with TC2013

Prepared by, date: PRE/MB, 2015-11-30 | Approved by, date: PRE/PC, 2015-11-30



Lab/Office:  
PRE

PROCESS INTERFACE ARISTOMIG  
OPTION BULLSEYE STANDALONE  
ROBOT 2

Status: Approved	Plant: = Location: + Sublocation: +
Document no. <b>3HEA803113-001</b>	Rev. Ind <b>03</b>
	Page 21 Next 22 Total 23

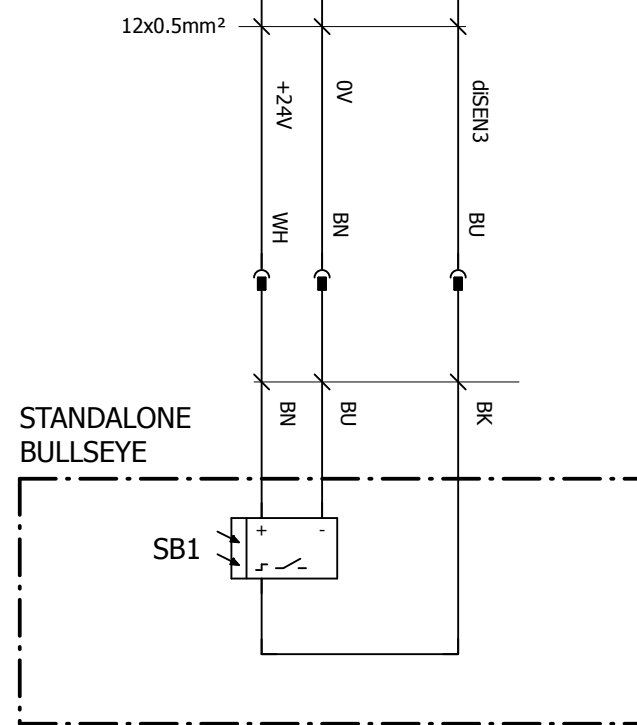
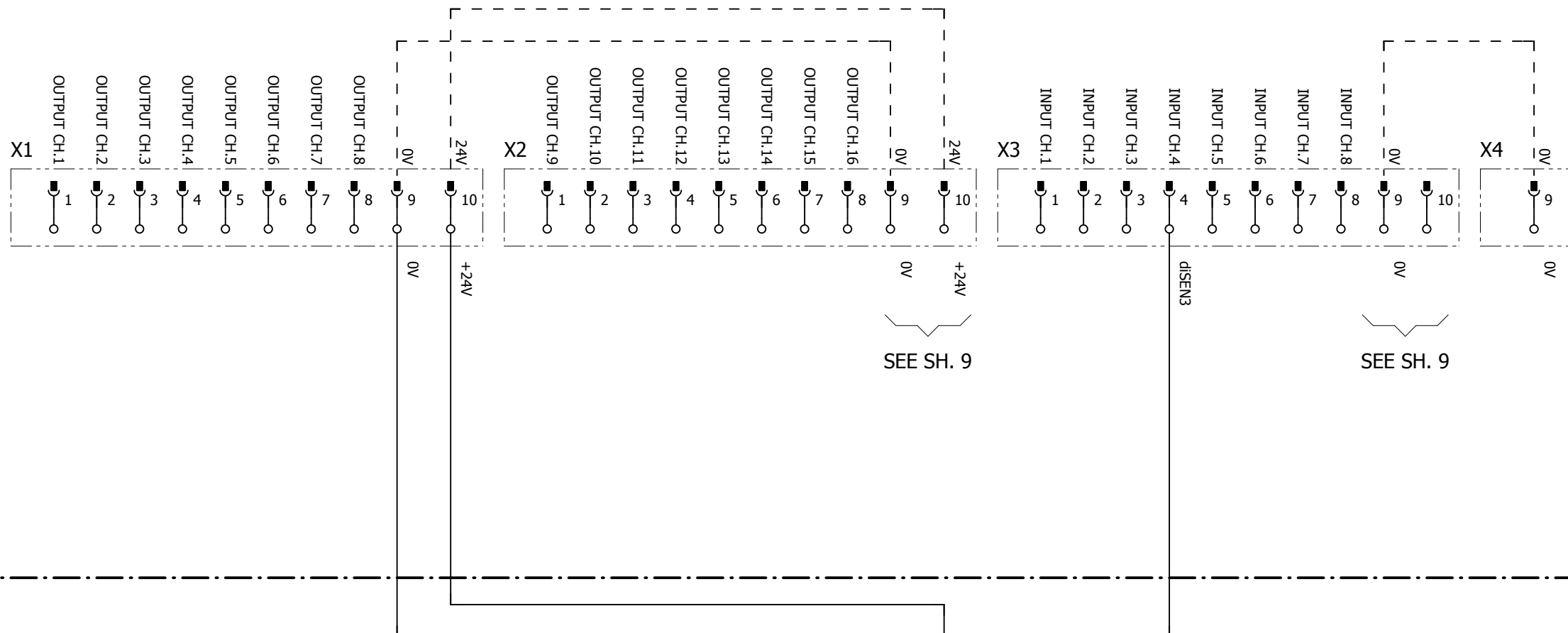

We reserve all rights in this document and in the information contained therein. Reproduction, use or disclosure to third parties without express authority is strictly forbidden. © Copyright 2003 ABB



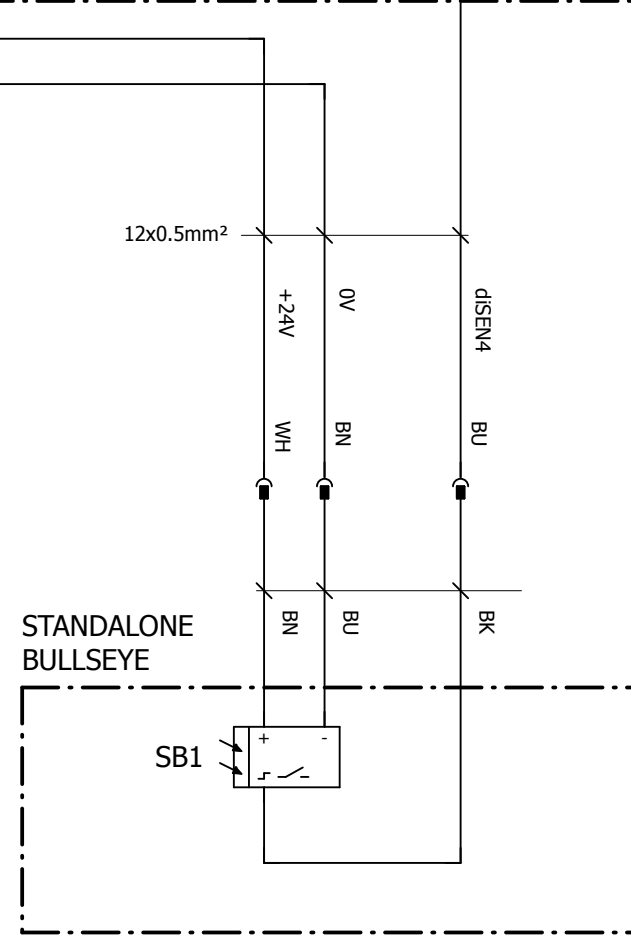
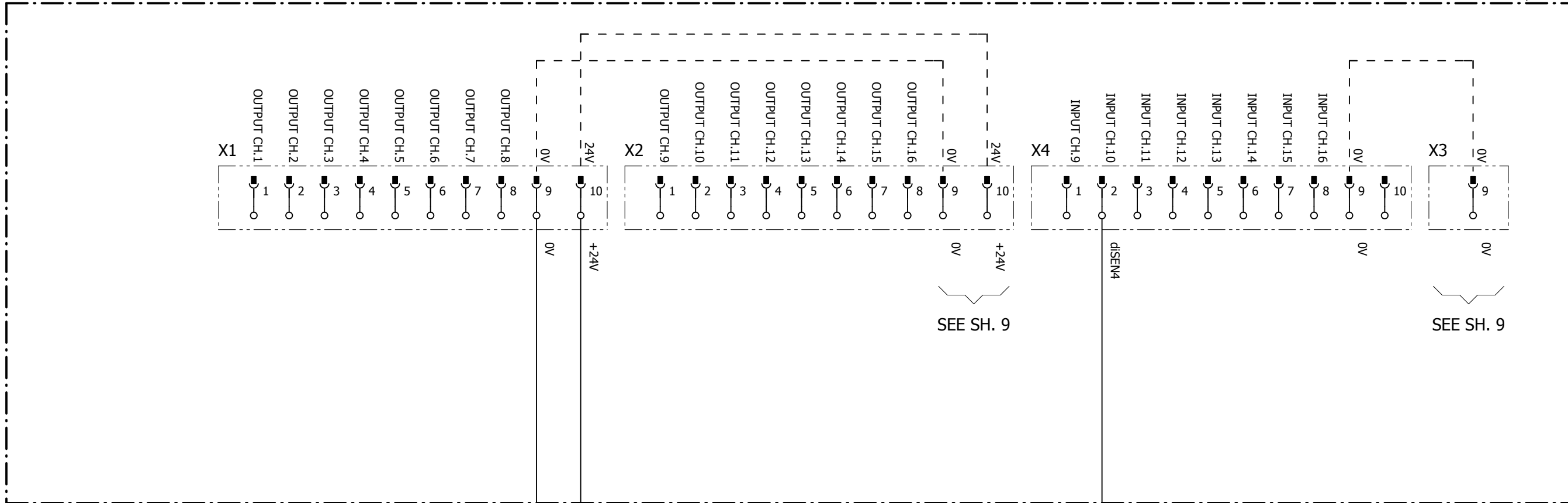

We reserve all rights in this document and in the information contained therein. Reproduction, use or disclosure to third parties without express authority is strictly forbidden. © Copyright 2003, ABB

